

# 7711994 - UNVENTED SYSTEM KIT

## MAXXflo & COMBIflo Water Heaters

### Fitting instructions

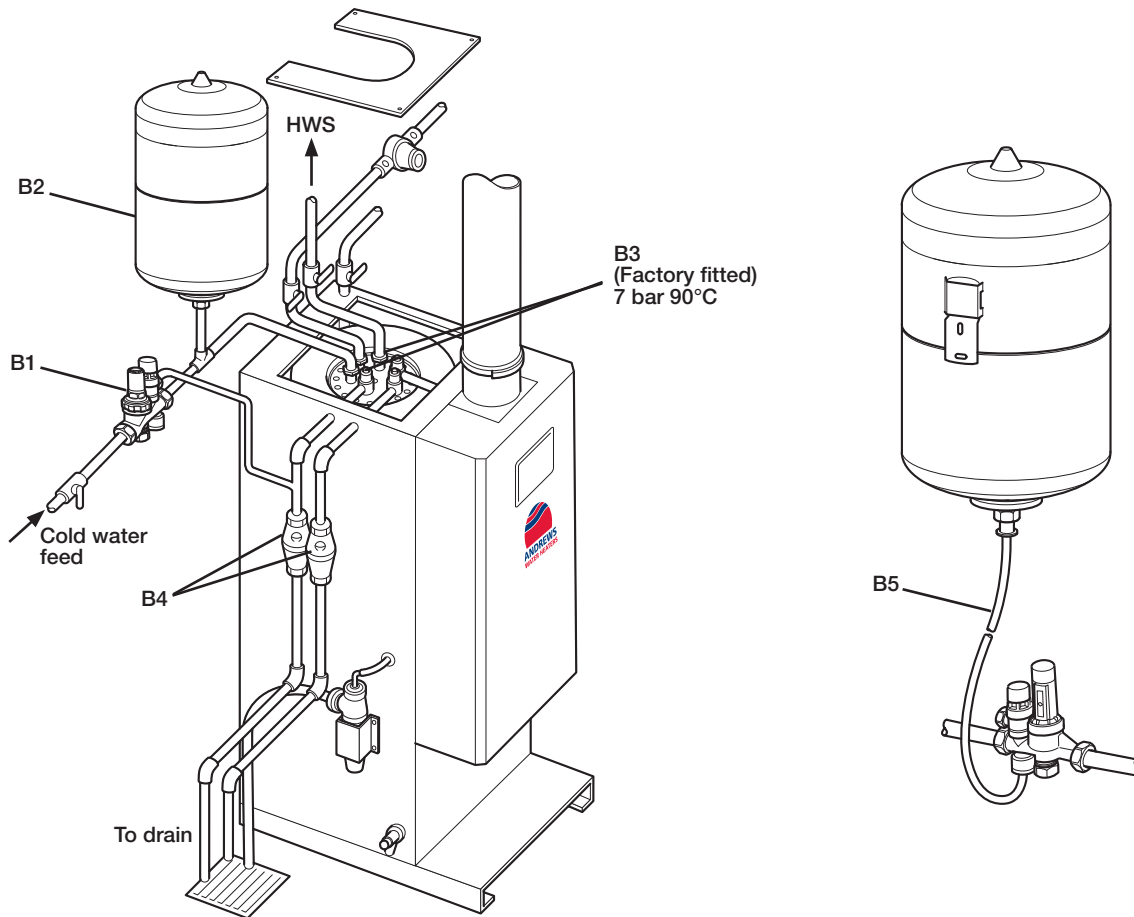

### Complete Unvented System Kit. Part No. 7711994 MAXXflo & COMBIflo (Comprising B1-B5)

Components	Andrews Part No.	Size
B1 One-piece Inlet Control (pressure reducing valve 3.5 bar, check valve, pressure relief valve 6 bar)	7705044	28mm comp
B2 Expansion Vessel (24 litre) c/w bracket	7705037	3/4" BSP
B3 Temperature/Pressure Relief Valve 7 bar/95°C (Factory fitted)	7705045	1" BSP
B4 Tundish (Supplied with the water heater)	7705047	1"-1 1/4" BSP
B5 Hose Assembly	7705041	3/4" BSP

*NB: Tees, elbow, stop valve and pipework not supplied*

Andrews MAXXflo Range Water Heaters are listed under the United Kingdom Water Regulations for use on unvented systems. Certificate number 1190044

Please read and understand these instructions before commencing installation and leave this manual with the customer for future reference.

**Andrews. Built to perform.**



This addendum is to be read in conjunction with the manufacturer's technical data and installation instructions.

Installation of unvented hot water systems must comply with Part G3 of the Building Regulations 2010.

Flush supply pipework to remove all flux and debris prior to fitting inlet controls.

Failure to do this may result in irreparable damage to the controls and will invalidate the warranty.

**NB: Item B1 is not adjustable**

#### **B1 One-piece Inlet Control Valve**

This combination incorporates: pressure reducing valve, single check valve, pressure relief valve and dedicated connection for an expansion vessel and balanced cold water connections.

The pressure reducing valve is set at 3.5 bar to control the operating pressure, and includes a wire gauze line strainer.

The check valve function prevents back-flow and ingress of hot water into the cold supply. In addition to the 28mm female threaded inline ports, the check valve housing incorporates a 22mm comp cold water take off and the 3/4" connection for an expansion vessel. The water pressure at this point will be similar to that available at the hot water outlet of the heater. If higher flow rates are required for the cold water services, a suitable 'tee' fitting should be incorporated upstream of B1.

An expansion relief valve is set to discharge at 6 bar, with a 22mm comp outlet. Not only does this limit the maximum system pressure to 6 bar, it also helps to indicate a malfunction in the system (eg expansion vessel fault, or cross-flow).

The expansion relief valve should be fitted with the discharge directed downwards or horizontally; if fitted in an inverted position, debris may be deposited on the seat of the valve and prevent full closure.

#### **One-piece Inlet Control Valve (continued)**

The easing knob on the valve should be operated periodically to ensure the valve is able to function.

There is a 1/4" gauge port to enable pressure gauge monitoring if required. If unused, the port should be sealed with the plugs supplied.

#### **B2 Expansion Vessel (24 litre)**

This vessel is designed to accommodate the expansion resulting from increased water temperature. The dry side of the diaphragm is charged to a pressure of 3.5 bar.

This pressure should be checked periodically, via the Schraeder-type valve on the top of the unit and if necessary, restored to 3.5 bar.

N.B: Water pressure must be relieved whilst checking and adjusting the pressure.

#### **B3 Combination Temperature/Pressure Relief Valve**

This opens at 95°C and/or 7 bar. Its principle function is to prevent the water temperature from, at any time, exceeding 100°C, in compliance with the Requirement G3 of the Building Regulations 2010.

#### **B4 Tundish**

To comply with the requirement G3 of the Building Regulations 2010 this must be installed within a distance of 500mm for the Temperature/Pressure relief valve.

When fitting B1 care must be taken to ensure that flow arrows, marked on the components, are pointing in the direction of water flow: i.e. towards the heater.

Please read and understand these instructions before commencing installation and leave this manual with the customer for future reference.

**Andrews. Built to perform.**



Sales 0345 070 1055

Technical 0345 070 1057

Web [andrewswaterheaters.co.uk](http://andrewswaterheaters.co.uk)

 [linkedin.com/company/andrews-water-heaters](https://www.linkedin.com/company/andrews-water-heaters)

 @AndrewsWH

Registered office address: Baxi Heating UK, Brooks House, Coventry Road, Warwick CV34 4LL

June 2020

Andrews. Built to perform.

## ALL TOGETHER BETTER



BAXI HEATING HAS A PORTFOLIO OF SOME OF THE BEST KNOWN AND MOST RESPECTED COMMERCIAL BRANDS IN THE HEATING INDUSTRY ACROSS THE UK AND IRELAND: • REMEHA, • ANDREWS WATER HEATERS, • POTTERTON COMMERCIAL AND • PACKAGED PLANT SOLUTIONS.

### BAXI HEATING COMMERCIAL BRANDS

The logo for Remeha, consisting of the word "remeha" in a bold, lowercase sans-serif font, with a yellow horizontal bar above and below the text.



The logo for Potterton Commercial, featuring the word "POTTERTON" in a bold, uppercase sans-serif font, with "COMMERCIAL" in a smaller, uppercase sans-serif font below it.



- **REMEHA** - ENGINEERING EFFICIENCY SINCE 1935  
Reliably engineering high-performance and high-efficiency heating solutions.
- **ANDREWS WATER HEATERS** - BUILT TO PERFORM  
UK's No. 1 commercial water heaters of choice for quality and reliability.
- **POTTERTON COMMERCIAL** - TOTALLY DEPENDABLE  
Heating solutions that customers can rely on and services they can trust.
- **PACKAGED PLANT SOLUTIONS** - INGENUITY BOXED  
Leading specialists in prefabricated plant rooms from concept to completion.